



# **R410A 50Hz 10HP Unit Series**

## **Technical Manual**

**2014 Version**



# Content

**PART 1.General Information ..... 1**

    1. Nomenclature .....2

    2. Model Names of Indoor/Outdoor Units .....3

    3. External Appearance .....4

**Part 2 Outdoor Unit..... 6**

    1.Features .....7

    2.Specification .....8

    3. Dimension .....10

    4. Service Space .....11

    5. Wiring Diagrams.....12

    6. Electric Characteristics.....13

    7. Exploded View .....14

    8. Operation Limits.....17

    9.Sound Levers .....18

**Part 3 Indoor Unit..... 19**

    1. Features .....20

    2. Specification.....23

    3. Dimensions .....24

    4. Service Space .....25

    5. Wiring Diagrams .....26

    6 Electric Characteristics .....28

    7 Accessories.....29

    8 The Specification of Wiring.....30

    9 Field Wiring.....31

    10. Exploded View .....32

    11.Trouble shooting .....36

**Part 4 Controller..... 37**

    1 Wireless Remote Controller .....38

    2 Wire Controller .....41

# PART 1.General Information

1.Nomenclature .....	2
2.Model Names of Indoor/Outdoor Units .....	3
3.External Appearance .....	4

# 1. Nomenclature

## 1.1 Indoor unit

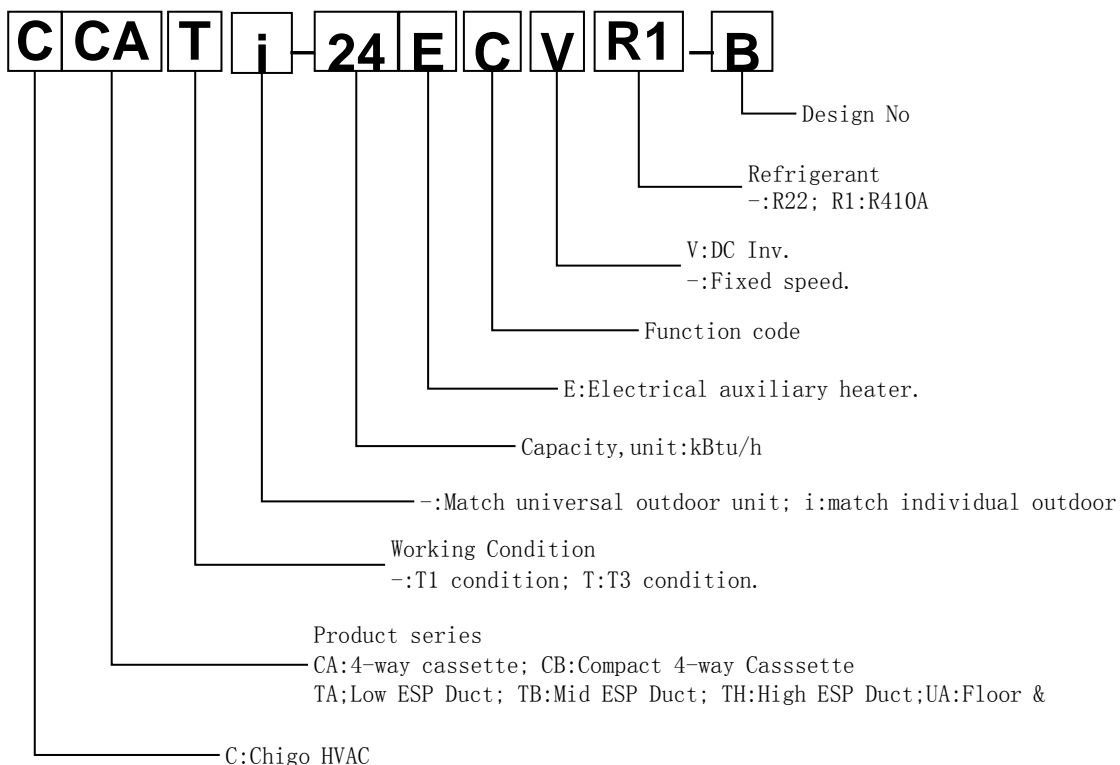

## 1.2 Outdoor unit

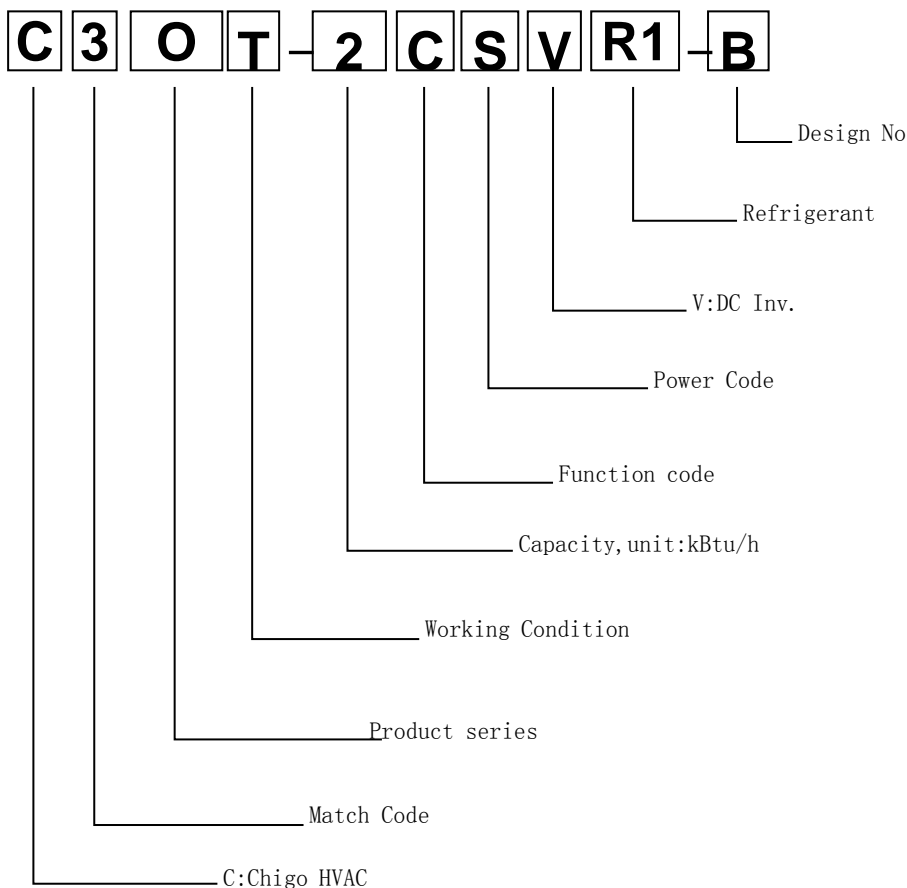

## 2. Model Names of Indoor/Outdoor Units

### 2.1 Indoor Units

Model name	Dimension (W×H×D) (mm)	Net/Gross weight(kg)	Power supply
Floor-standing indoor unit			
CFAi-96HR1	1200×1855×380	120/124	220~240V/1Ph/50Hz
High ESP ducted outdoor unit			
CTHi-96HR1	1440×811×448	100/104	220~240V/1Ph/50Hz

### 2.2 Outdoor Units

Model name	Dimension (W×H×D) (mm)	Net/Gross weight(kg)	Power supply
COT-96HZR1	970×765×1620	194/200	380~415V/3Ph/50Hz

## 3. External Appearance

### 3.1 Indoor unit

Floor-standing Indoor unit



High ESP Ducted indoor Unit



### 3.2 Outdoor unit



96k Btu/h

---

## Part 2 Outdoor Unit

1.Features .....	7
2.Specification .....	8
3. Dimension .....	10
4.Service Space .....	11
5. Wiring Diagrams .....	12
6. Electric Characteristics .....	12
7. Exploded View .....	14
8. Operation Limits .....	17
9.Sound Levers .....	18



# 1.Features

1.Famous scroll compressor with quick reactivity, stronger power and operation stable. Anti-attention design and better low-temperature heating performance.



2.New panel and plastics safe guard of outdoor unit.



3. The diameter of globe valve is DN8mm



4. New 10HP Universal Outdoor Unit, compact appearance molding, same as the 10Hp outdoor unit of New VRF.

5. Single fan and top discharge design ,smaller floor area, better for container capacity.

6. Forward swept wing anti-butter axial fan and dedicated mute duct design, better running sound, less noise pollution.

## 2.Specification

Model		COT-96HZR1	
Power supply		V-Ph-Hz	380~415V/3PH/50Hz
Cooling	Capacity	kW	28
		Btu/h	96000
	Input	W	9400
	Rated current	A	16
Heating	Capacity	kW	28
		Btu/h	105000
	Input	W	9000
	Rated current	A	15.3
Max. input consumption		W	13000
Max. current		A	24.3
Starting current		A	66
Compressor	Model		C-SB373H8D
	Type		Scroll
	Brand		SANYO
	Capacity	W/(Btu/h)	14100/48109
	Input	W	4750
	Rated current(RLA)	A	8.22
	Locked rotor Amp(LRA)	A	66
	Thermal protector		Internal
	Capacitor	μF	/
	Refrigerant oil	ml	1700
Outdoor motor fan	Model		YDK-450-6P3
	Output	W	450×1
	Capacitor	μF	25×1
	Speed (H/L)	r/min	840/620
Outdoor coil	Number of rows		2×28U
	Tube pitch(a)x row pitch(b)	mm	22×19.05
	Fin spacing	mm	1.6
	Fin type		Hydrophilic Aluminum
	Tube outside dia.and type	mm	7.94
			Inner grooved
	Coil length x height x width	mm	1990×1253×38
Number of circuits		2×10	
Outdoor air flow		m <sup>3</sup> /h	12000
Outdoor noise level		dB(A)	63
Outdoor unit	Dimension(W*H*D)	mm	970×765×1620
	Packing (W*H*D)	mm	1030×825×1750
	Net/Gross weight	kg	194/200
Refrigerant type(R410a)/quantity		g	2×5000
Throttle part			Capillary

Design pressure		MPa	4.0/1.2
Max pressure		MPa	4.5
Refrigerant piping	Liquid side/ Gas side	mm	Φ9.52/Φ19.05
	Max. pipe length	m	50
	Max. difference in level	m	20
Ambient temp		°C	-7~43

### 3. Dimension

COT-96HZR1

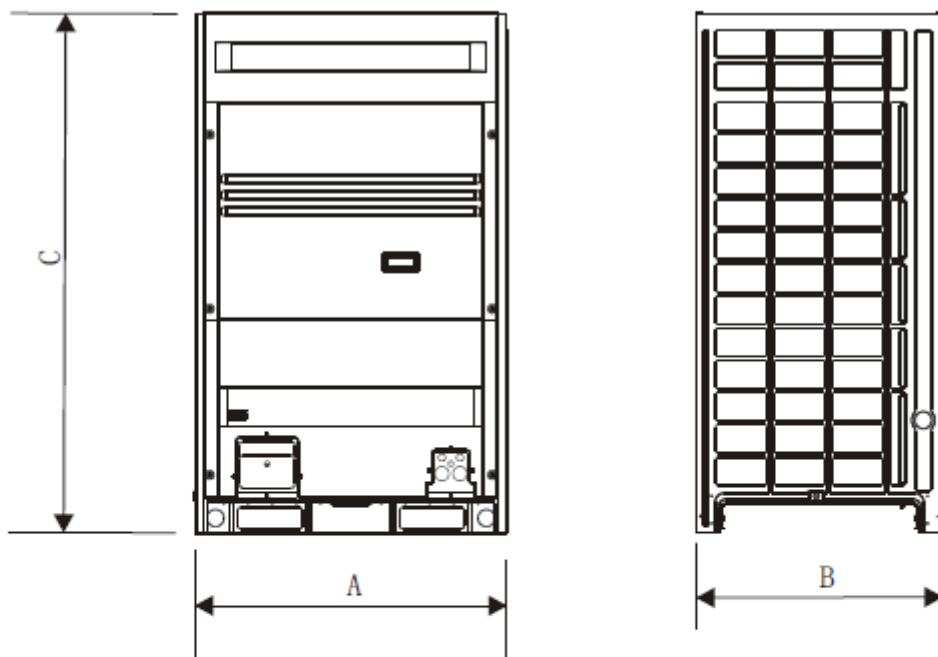

Model (kBTu/h) \ Items	A	B	C
96	970	765	1620

## 4. Service Space

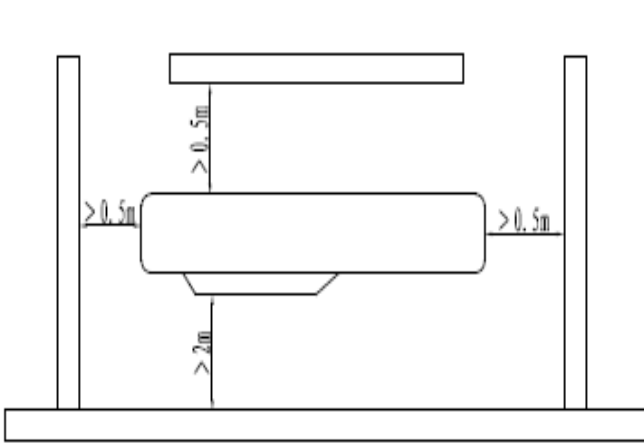

Fig 13

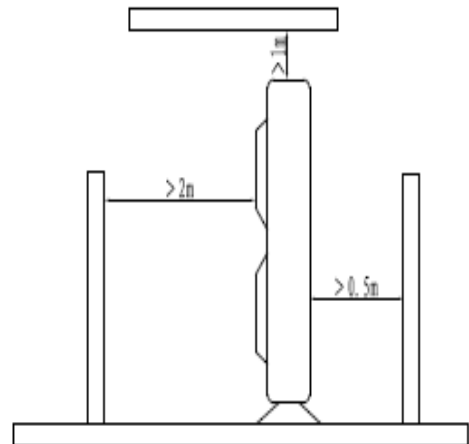
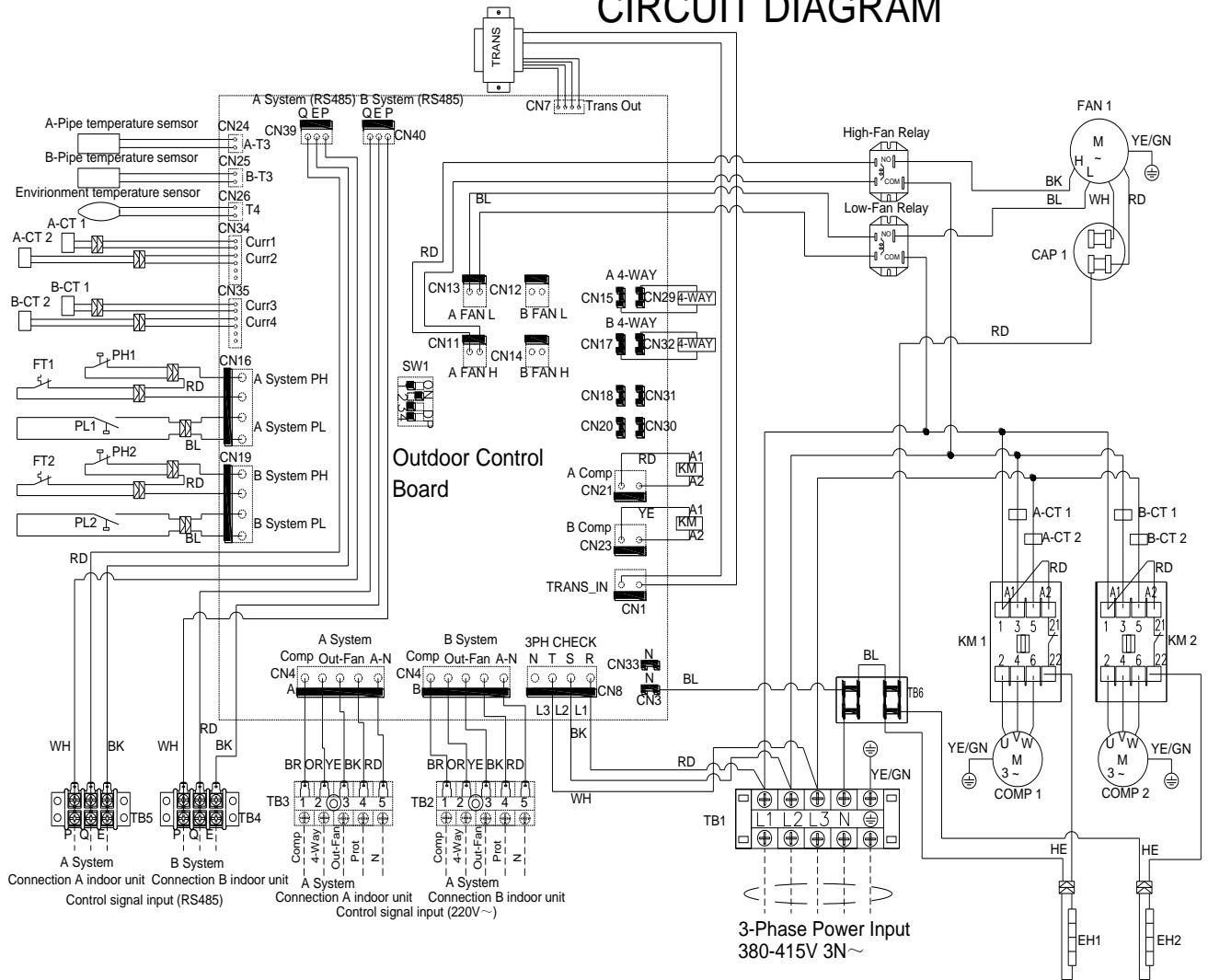

Fig 14

# 5. Wiring Diagrams

## COT-96HZR1

### CIRCUIT DIAGRAM



---

## 6. Electric Characteristics

Model	Indoor Units				Outdoor Fan Motor
	Hz	Voltage	Min.	Max.	kW
<b>COT-96HZR1</b>	50	380-415V	342V	418V	0.45

## 7. Exploded View

### COT-96HZR1

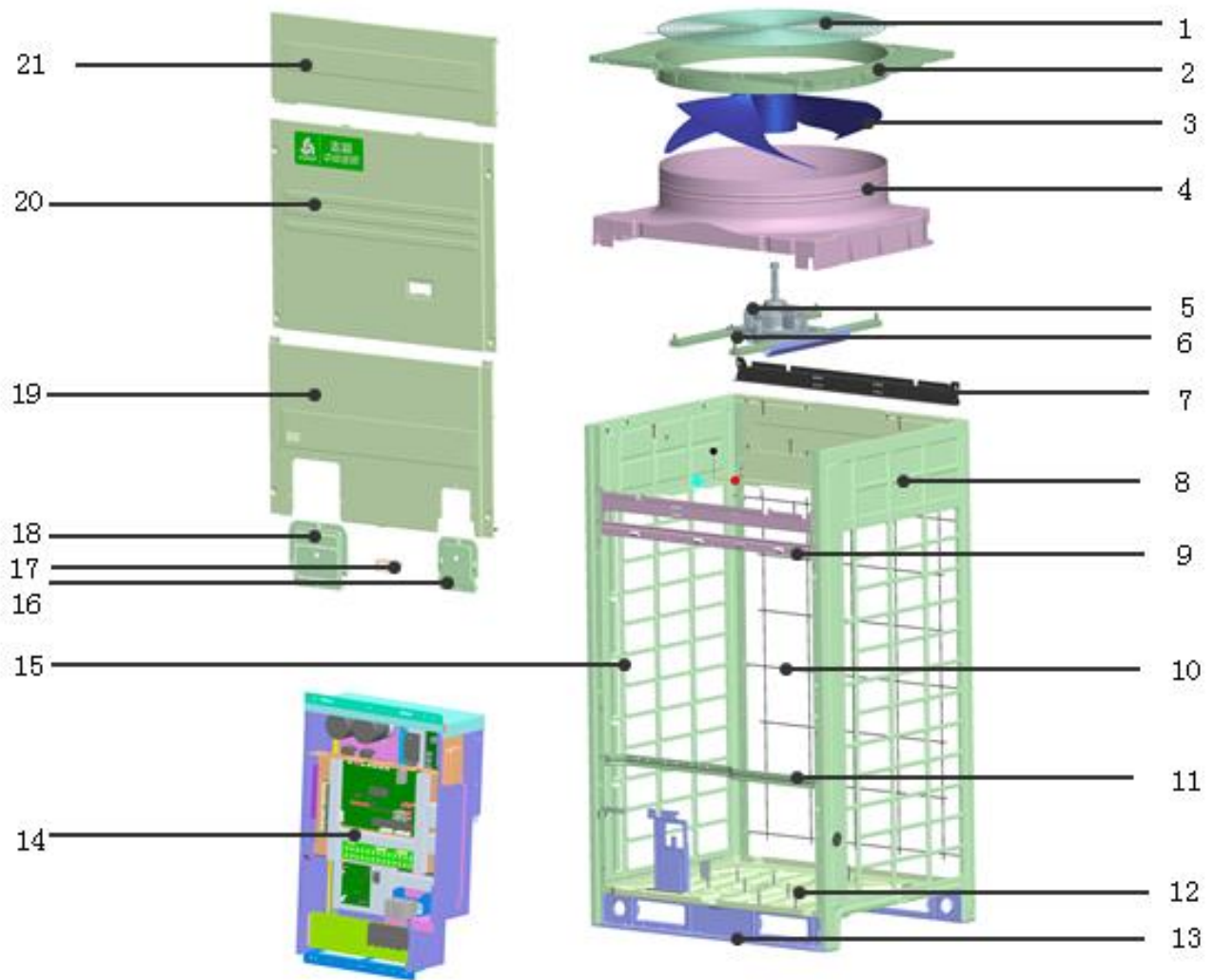



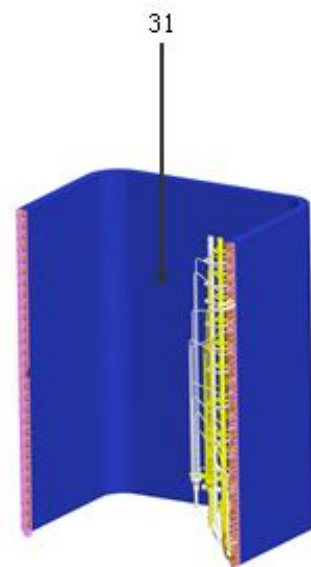
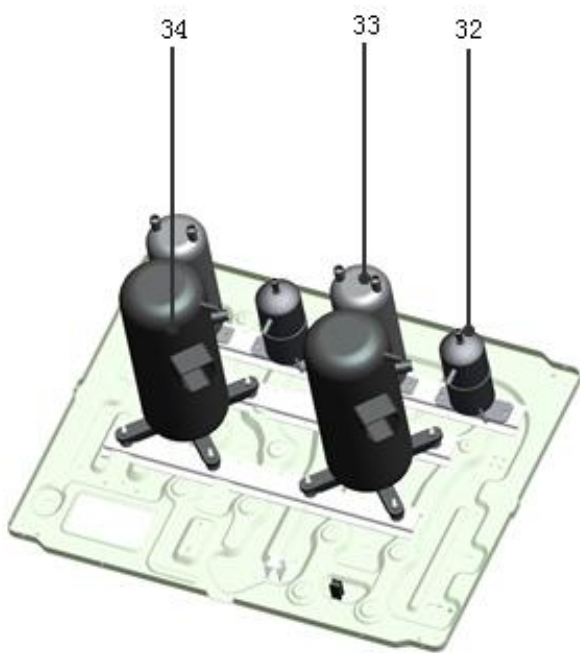
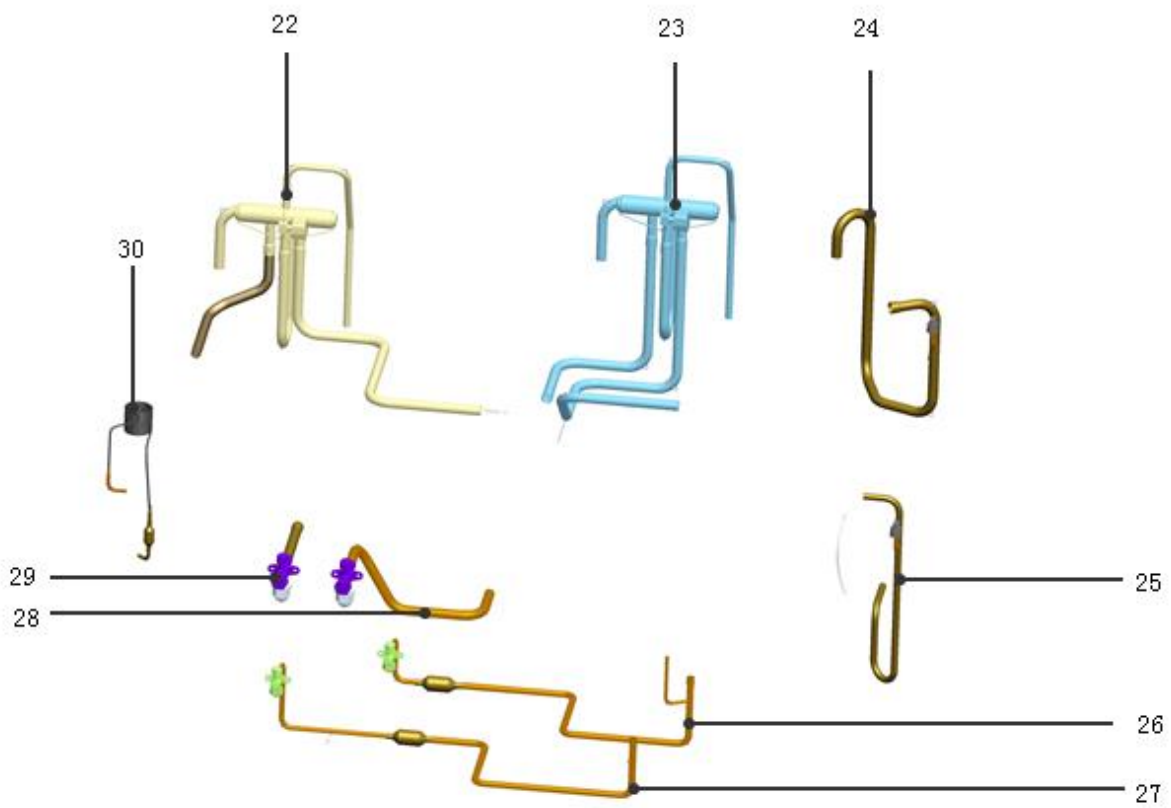

No.	Part Name	Quantity	No.	Part Name	Quantity
1	Top net	1	18	The pipe cover1	1
2	Cover	1	19	down panel	1
3	Propeller fan	1	20	middle panel	1
4	Inlet cone components	1	21	Top panel components	2
5	Fan motor	1	22	left 4-Ways valve assy	1
6	Holder for fan motor	2	23	right 4-Ways valve assy	1
7	Back beam	1	24	Press inspiratory tube components	2
8	Right cover	1	25	Exhaust the toal component	1
9	Front top beam	1	26	Lfet High pressure cut-off assembly	1
10	Back net	1	27	Right High pressure cut-off assembly	1
11	Front down beam	1	28	left cut-off assembly	1
12	base assy	1	29	right cut-off assembly	1
13	Machine feet	2	30	The oil return capillary assembly	2
14	E-parts, assy	1	31	condenser assy	1
15	Right cover	1	32	Oil separator	2
16	The pipe cover2	1	33	Vapour separator	2
17	Pumping hands	1	34	compressor	2

---

## 8. Operation Limits

Operation mode	Outdoor temperature(°C)	Room temperature(°C)
Cooling operation	-7~43	17~30
Heating operation	-7~30	17~30

## 9.Sound Levels

Outdoor Unit

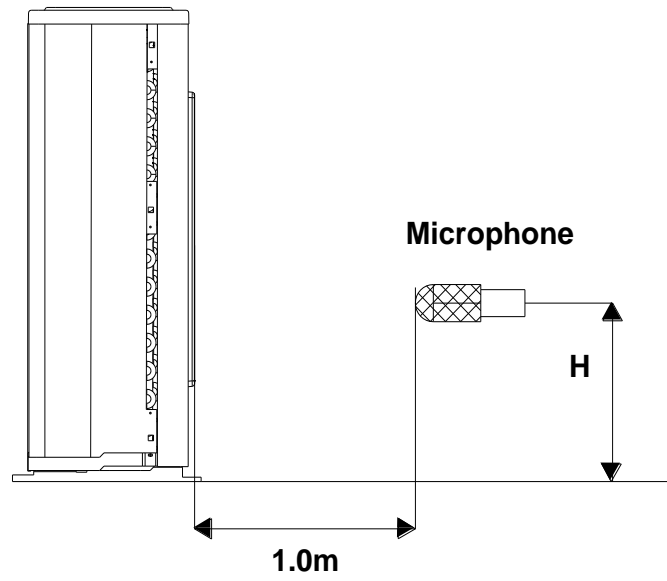

Model	Noise level dB(A)
COT-96HZR1	63

---

## Part 3 Indoor Unit

1.Features .....	20
2.Specification .....	23
3. Dimensions.....	24
4.Service Space .....	25
5. Wiring Diagrams .....	26
6.Electric Characteristics .....	28
7. Accessories .....	29
8.The Specification of Wiring.....	30
9.Field Wiring .....	31
10. Exploded View.....	32
11. Trouble shooting .....	36

# 1. Features

## 1.1 CTHi-96HR1

1. Centrifugal fan, low noise and big airflow.

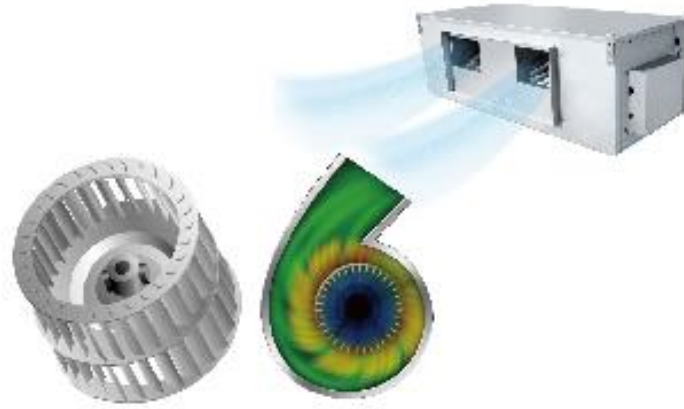

2. Max. refrigerant pipe length is 50m. Max. difference in height 20m.

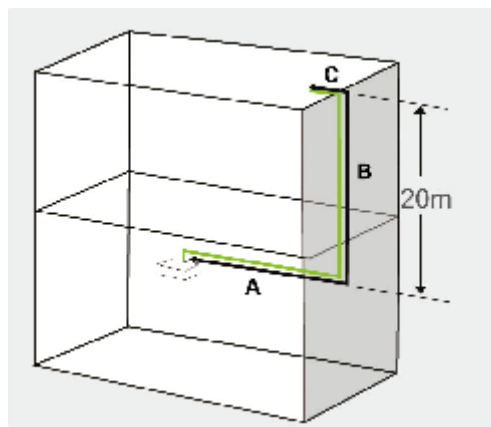

3. Rated ESP is 120Pa, flexible air duct installation.

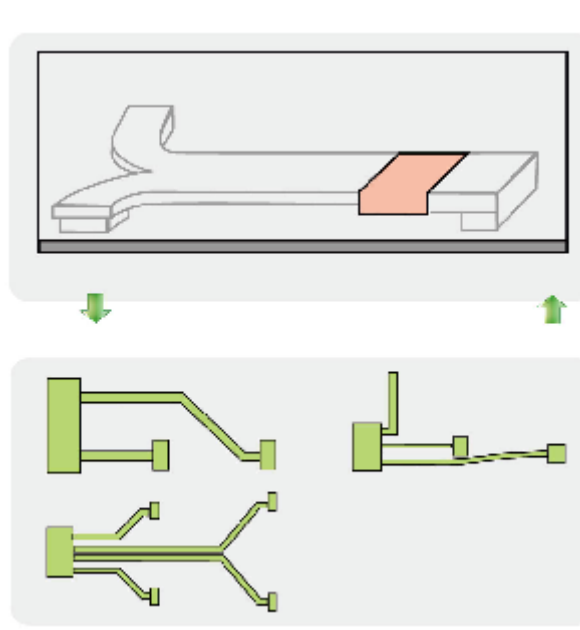

4. standard for wired controller, optional for wireless controller.



## 1.2 CFAi-96HR

1. Brand-new panel design simple, featly and vogueish appearance suit different requirement. It's mostly used for office, shopping center, restaurant, meeting room and etc..

Aviation centrifugal fan. Double CFD technology design, increasing air-volume and decreasing noise level.

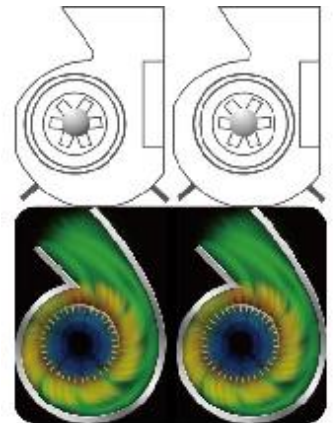

2. New air flow system, Larger heat-exchanging area, Higher efficiency of the evaporator.

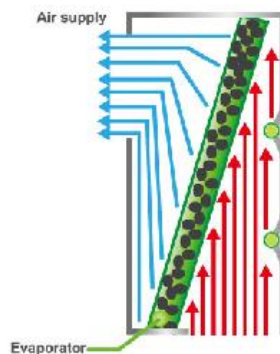

3. Standard for horizontal air flow, cold air can reach each corner of the room, providing a stable and comfortable environment.



4. Plastics centrifugal fan, suitable blades, low noise and big flow.

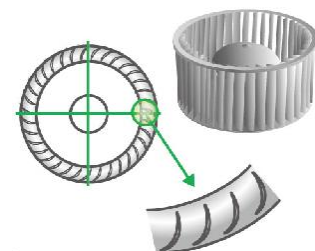

5. Optional control panel, meeting different requirements.



Standard

6. Slim body, the depth of the body is only 380mm.



Optional

7. Easy and convenient installation and maintenance.

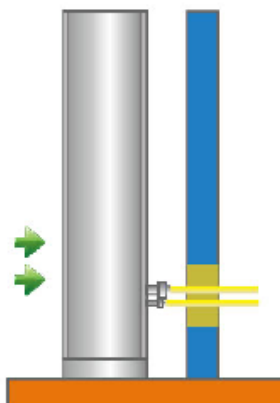



## 2. Specification

Model			CTHi-96HR1	CFAi-96HR1
Power supply		V-Ph-Hz	220-240V/1PH/50Hz	220-240V/1PH/50Hz
Cooling	Capacity	Kw	28	28
		Btu/h	96000	96000
	Input	W	1200	740
	Rated current	A	5.6	3.5
	EER	W/W	2.64	2.76
Heating	Capacity	Kw	30	30
		Btu/h	105000	105000
	Output	W	1200	740
	Rated current	A	5.6	3.5
	COP	W/W	2.94	3.08
Indoor fan motor	Model		YDK-300F-4P3	YDK-155-8P3
	output	W	2×300	2×155
	Capacitor	μF	15+15	10+10
	Speed(hi/mi/lo)	r/min	1050/920/820	600/550/450
Indoor coil	Number of rows		4 , 28U	8 , 32U
	Tube pitch(a)x row pitch(b)	mm	25×21.65	25×21.65
	Fin spacing	mm	1.5	1.5
	Fin type		Hydrophilic Aluminum	Hydrophilic Aluminum
	Tube outside dia. and type	mm	Φ9.52	Φ9.52
			Inner grooved	Inner grooved
	Coil length x height x width	mm	1200×410×86.6	980×800×48
Number of circuits		4+4	4+4	
Indoor air flow		m3/h	4400	4000
Static Pressure		Pa	120	0
Indoor noise level		dB(A)	45-55	55
Indoor unit	Dimension (W*H*D)	Body(mm)	1440×811×448	1200×1855×420
	Packing (W*H*D)	Body(mm)	1595×855×560	1290×1980×452
	Net/Gross weight	Body (Kg)	100/104	120/135
Refrigerant type			R410a	R410A
Refrigerant piping	Liquid side/ Gas side	mm	Φ9.52/Φ19.05	Φ9.52/Φ19.05
Connection wiring	Power wiring	mm2	5×4.0/3×1.5	5×4.0/3×1.5
	Signal wiring	mm2	5×0.75	5×0.75
Controller			Wired controller	Wireless controller
Operation temp		°C	16 ~ 32	16 ~ 32
Ambient temp		°C	-7 ~ 43	-7 ~ 43

### 3. Dimensions

#### CTHi-96HR1

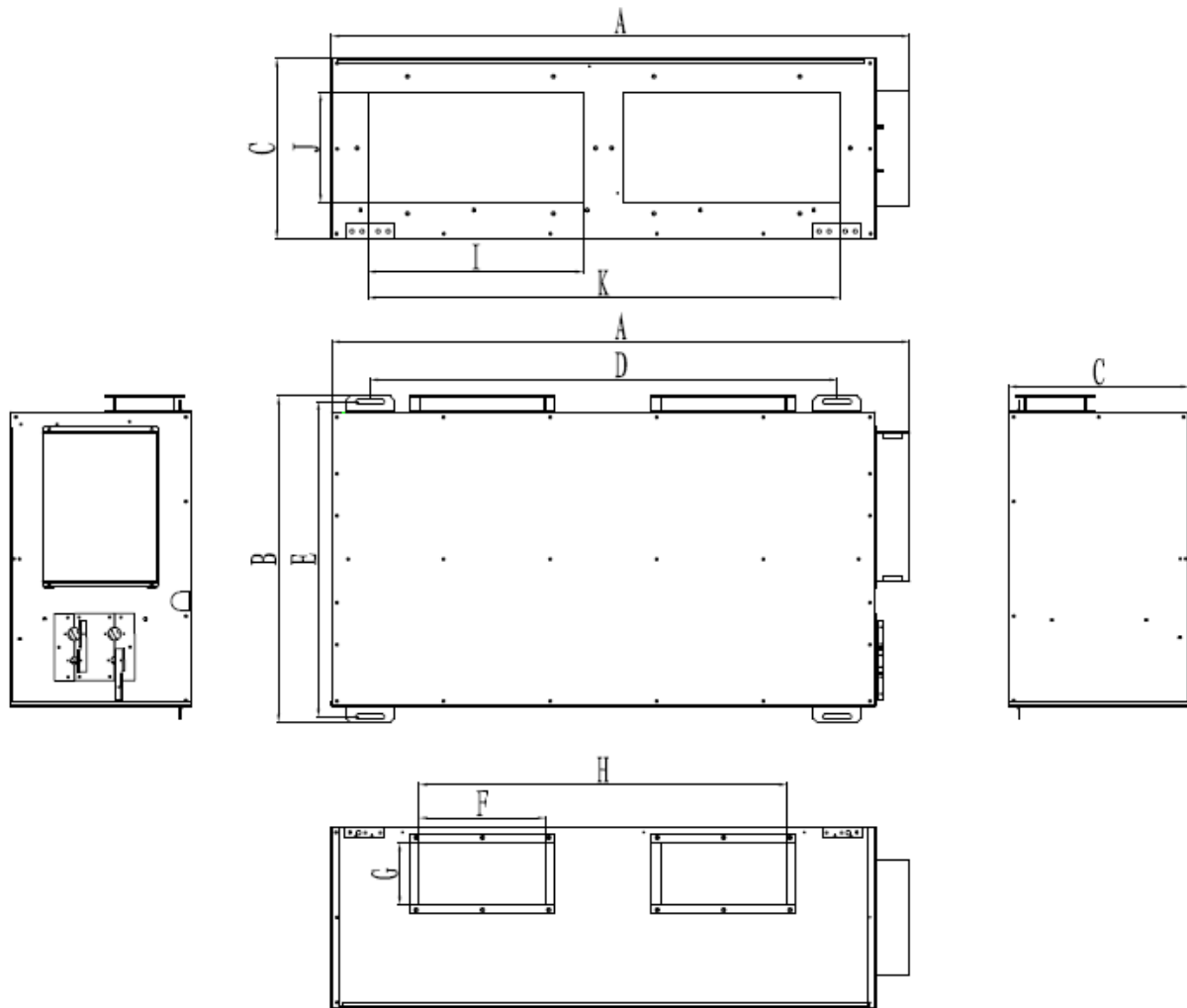

Table 4: unit : mm

Model(kBtu/h)	Items	A	B	C	D	E	F	G	H	I	J	K
96		1440	811	448	1162	784	300	150	900	537	272	1174

---

## 4. Service Space

Ensure enough space required for installation and maintenance.

CTHi-96HR1

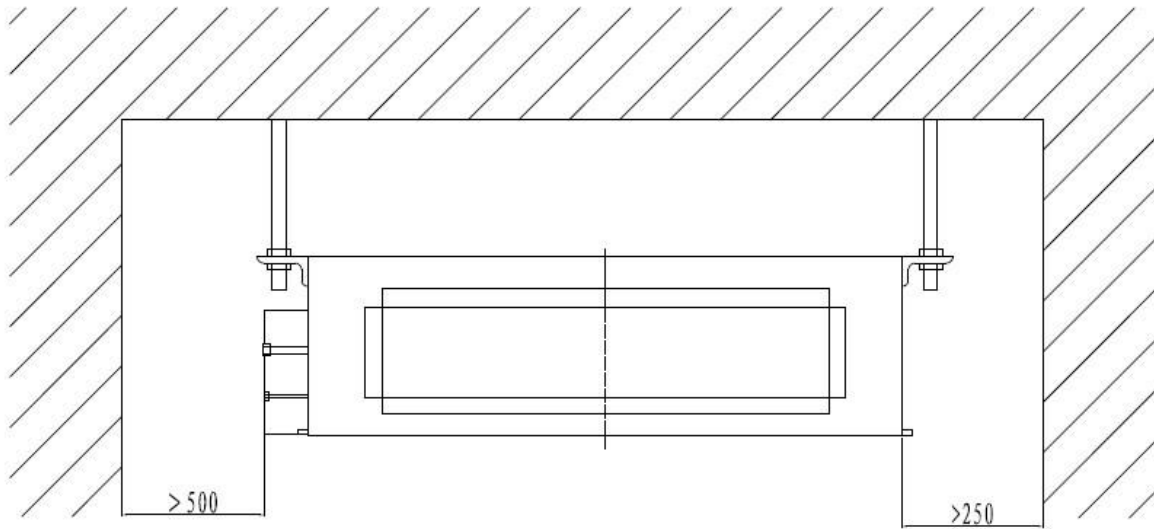

# 5. Wiring Diagrams

## 5.1 CTHi-96HR1

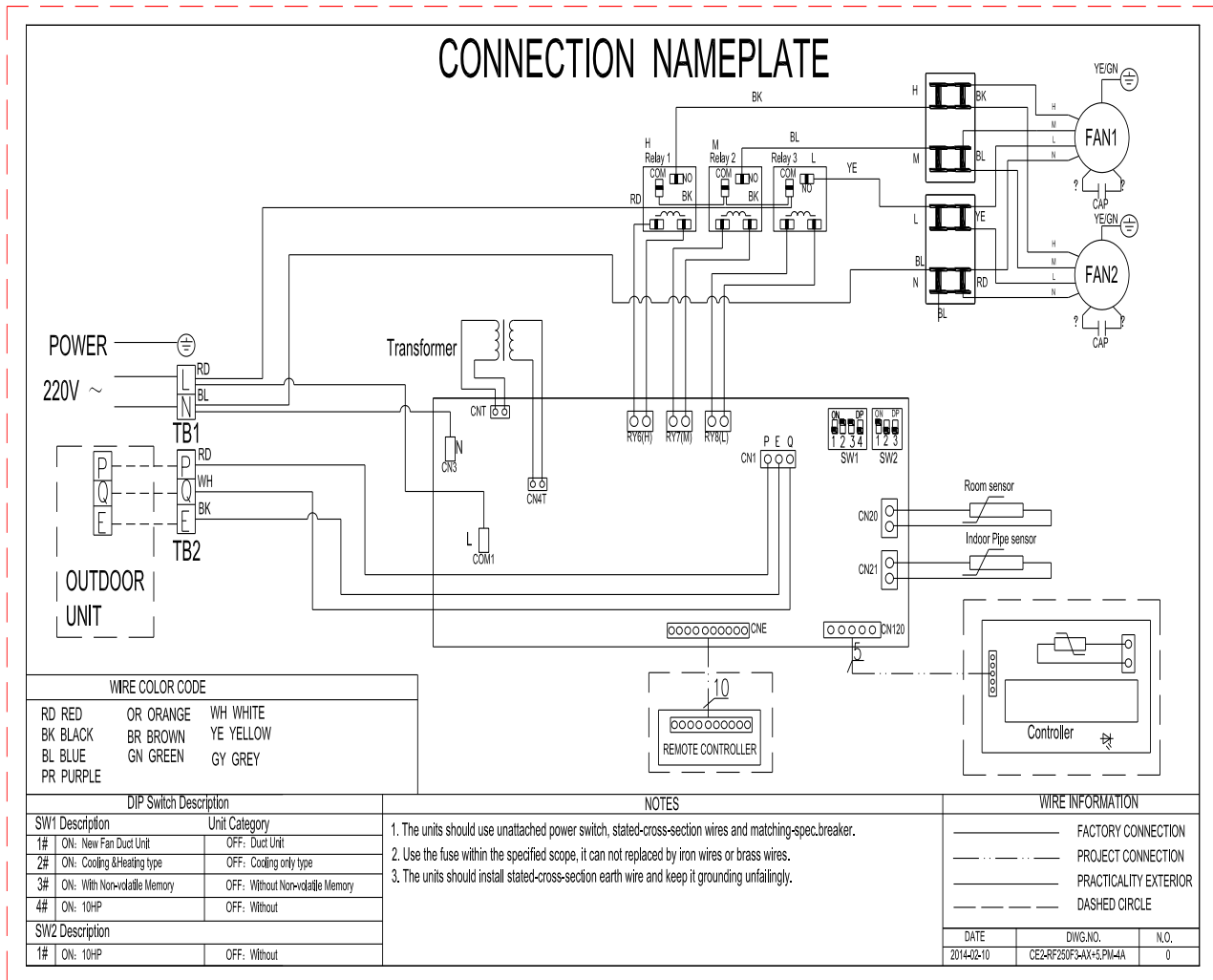

## 5.2 CFAi-96HR1

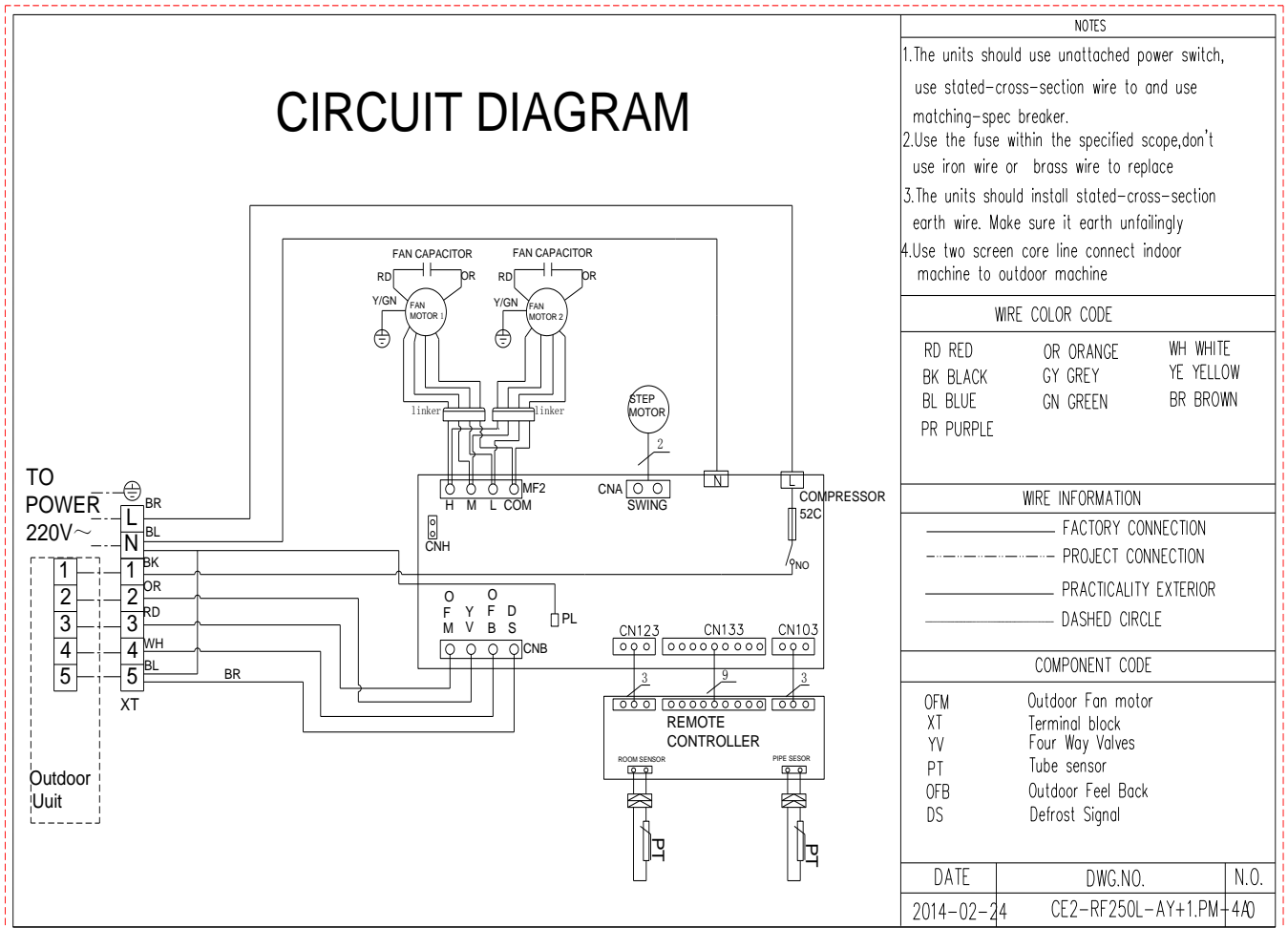





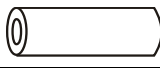

---

## 6 Electric Characteristics

Model	Indoor Units				Indoor Fan Motor
	Hz	Voltage	Min.	Max.	kW
CTHi-96HR1	50	220-240V	198V	254V	0.6
CFAi-96HR1	50	220-240V	198V	254V	0.31

## 7 Accessories

	Name	Shape	Quantity
Tubing & Fittings	Soundproof/insulation sheath		2
	Binding tape		1
	Seal sponge		1
Drainpipe Fittings	Seal ring		1
	Remote controller (optional)		1
others	Operation & installation instruction manual		1

## 8 The Specification of Wiring

Model		CTHi-96HR1	CFAi-96HR1
Indoor power supply	V/Ph/Hz	220~240/1/50	
Outdoor power supply	V/Ph/Hz	380~415/3/50	
Connection wiring	Outdoor Power Supply		Power supply individually for indoor and outdoor
	Power wiring	mm <sup>2</sup>	5×4.0/3×1.5
	Signal wiring	mm <sup>2</sup>	5×0.75



## 9 Field Wiring

CTHi-96HR1

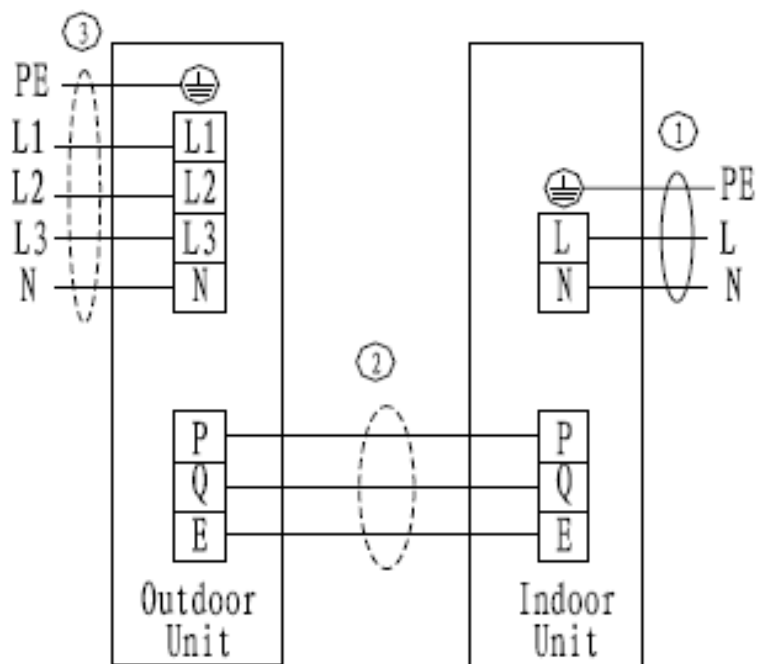

# 10. Exploded View

## CTHi-96HR1

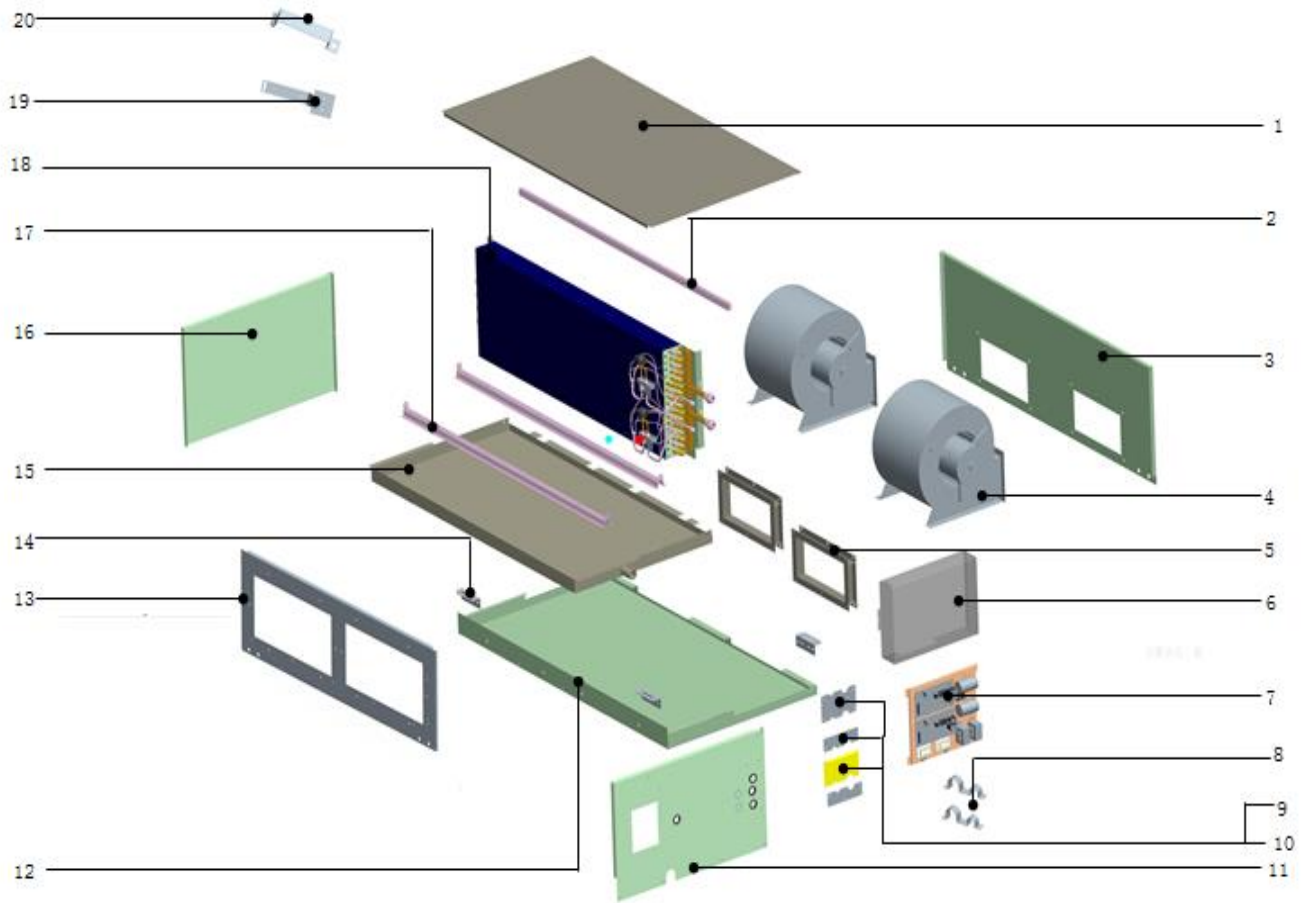

No.	Part Name	Quantity	No.	Part Name	Quantity
1	Top cover plate attached to the cotton component	1	9	Lid A welded assemblies	1
1.1	Top cover plate	1	10	Lid B welded assemblies	1
2	Reinforcing plate	1	11	Left panel affixed cotton parts	1
3	Air out board attached to the cotton	1	11.1	Left side board	1
3.1	Air out board assy	1	12	Chassis paste cotton parts	1
3.1.1	Air out board	1	13	Air return panel assy	1
4	Motor bracket assembly	1	13.1	Air return panel	1
4.1	Indoor motor	2	14	Hook	4
4.2	The fan assembly	2	15	The water tray Sticker cotton parts	1
5	Flange affixed cotton parts	2	15.1	The water tray assy	1
5.1	Flange welded components	2	16	Right panel affixed cotton parts	1
6	E- parts box cover	1	16.1	Right side board	1
7	Eletronic control components	1	17	Motor bracket assembly	2
7.1	Electrical mounting plate	1	18	Evaporator parts	1
7.2	Compressor capacitor	2	18.1	Evaporator assy	1
7.3	Relays	3	18.2	Manifold assembly	2
7.4	PCB components	1	18.3	Split head A assembly	1
7.5	Terminal	1	18.4	Split head B assembly	1
7.6	Terminal	1	19	Throttle assembly bracket	1
8	Pipe clamps	2	20	Throttle assembly retaining clips	1
8.1	Pipe clamps1	2			

# CFAi-96HR1

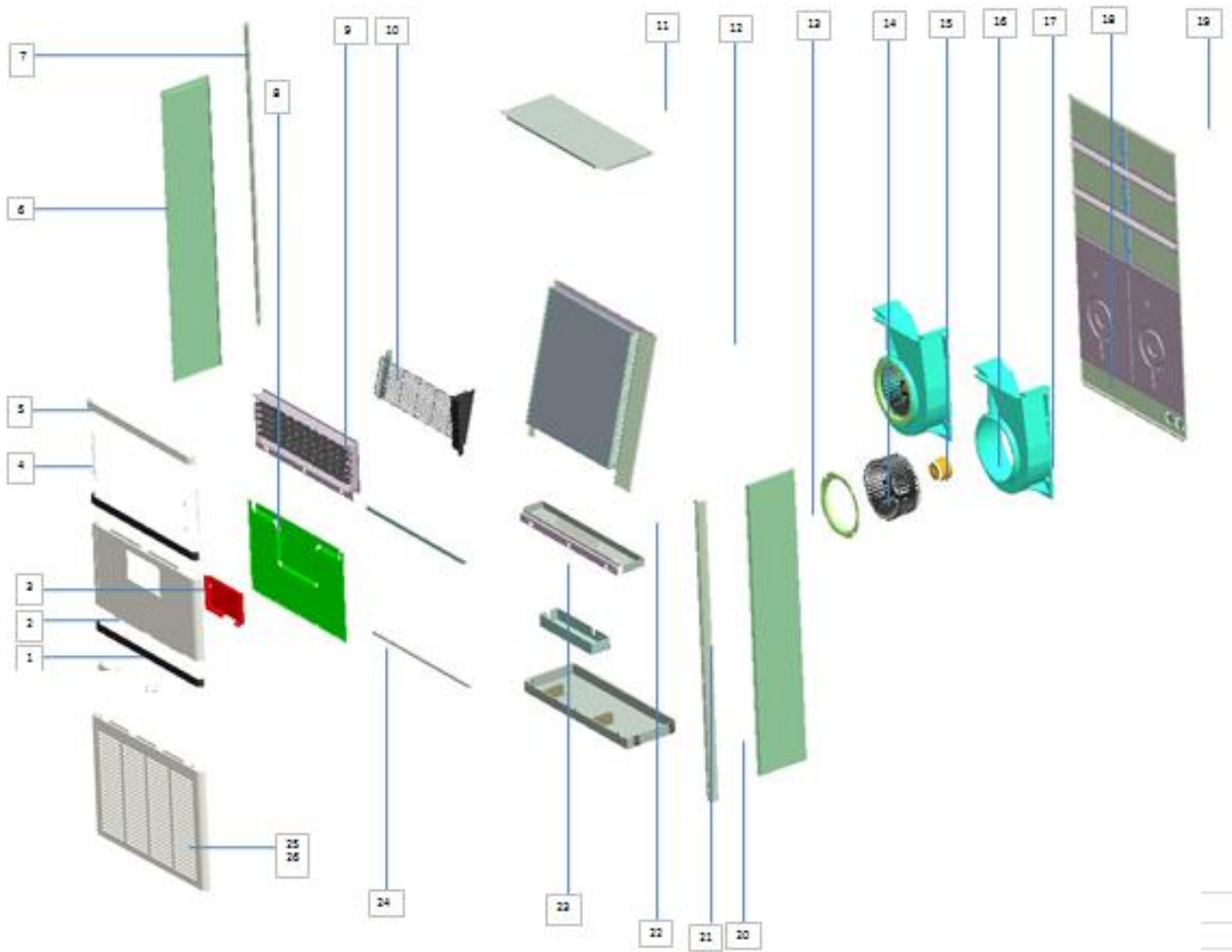

No.	Part Name	Quantity	No.	Part Name	Quantity
1	Bottoms decorations components	2	12.5	Gas collector component A	1
2	Front panel assembly	1	12.6	The left seal plate	1
3	Display box component	1	12.7	The right seal plate	1
3.1	Tan transparency	1	12.8	Up seal plate	1
3.2	Display frame	1	12.9	Down seal plate	1
3.3	Operating screen	1	13	The right column weldment	1
4	The wind gate side panel	2	14	right-side plate	1
5	Up trim strip	1	15	Return air cover	2
6	left side plate	1	16	Centrifugal rotor	2
7	The left column weldment	1	17	Indoor motor	2
8	clapboard	1	18	Spiral duct	2
9	The wind gate parts	1	19	Backplane components	1
9.1	Tuyere framework components	1	20	Foundation assembly	1
9.2	Leaf blade card buckle	24	21	electronic control components	1
9.3	Put the wind vane	12	21.1	Indoor electric control	1
9.4	Article blade connection	2	21.3	termianl	1
9.5	crankshaft	1	21.4	Electric control board plastic base	1
9.6	A synchronous motor	1	21.5	Insert the fan capacitance	2
9.7	synchronous motor	1	21.6	ELECTRIC CONTROL BOX	1
9.8	Anti-rotating plastic buckle	10	21.7	cover of electric control box	1
9.9	Cross ventilation components	5	21.8	No. 3 line pressing buttons	1
11	lamina tecti	1	22	Water pans components	1
12	The evaporator components	1	23	The up filter tank	1
12.1	Gas collector component B	1	24	The down filter tank	1
12.2	The evaporator throttle component A	1	25	Filter	1
12.3	The evaporator throttle component B	1	26	Return air panel	1
12.4	The evaporator components	1			

## 11.Trouble shooting

### Fault code table

CTHi-96HR1

<b>4LED Faults</b>	<b>Digital display</b>	<b>Failure description</b>
Timer light flashing	E2	Ambient temperature sensor (T1) failure
Running light flashing	E3	Evaporator pipe temperature sensor (T2) failure
Defrost light flashing	E5	Condenser pipe temperature sensor (T3) failure
Warning light flashing	F5	Water fullfilled protection
Running light, defrost light flashing	E1	Indoor unit and wire controller communication failure
Running light, timer light flashing	P6	Indoor unit EEPROM failure
Defrost light, timer light flashing	F0	Indoor fan stall protection
Defrost light, warning light flashing	F2	Outdoor protection
	F7	outdoor unit over-current protection
Timer light, warning light flashing	E0	Indoor unit and outdoor unit communication failure
Running light, defrost light, timer light flashing	F3	High pressure protection
Defrost light , timer light, warning light flashing	F4	Low pressure protection
Running light, timer light, warning light flashing	F8	Outdoor unit exhaust temperature over-high protection
Running light, defrost light, timer light, warning light flashing	F9	Three-phase electricity phase sequence failure
Note: the flashing frequency for all above indication lights is 1HZ.		

## Part 4 Controller

1.Wireless Remote Controller.....	38
2.Wire Controller .....	41

# 1 Wireless Remote Controller

## 1.1 Jingling TB-YKQ-D02b

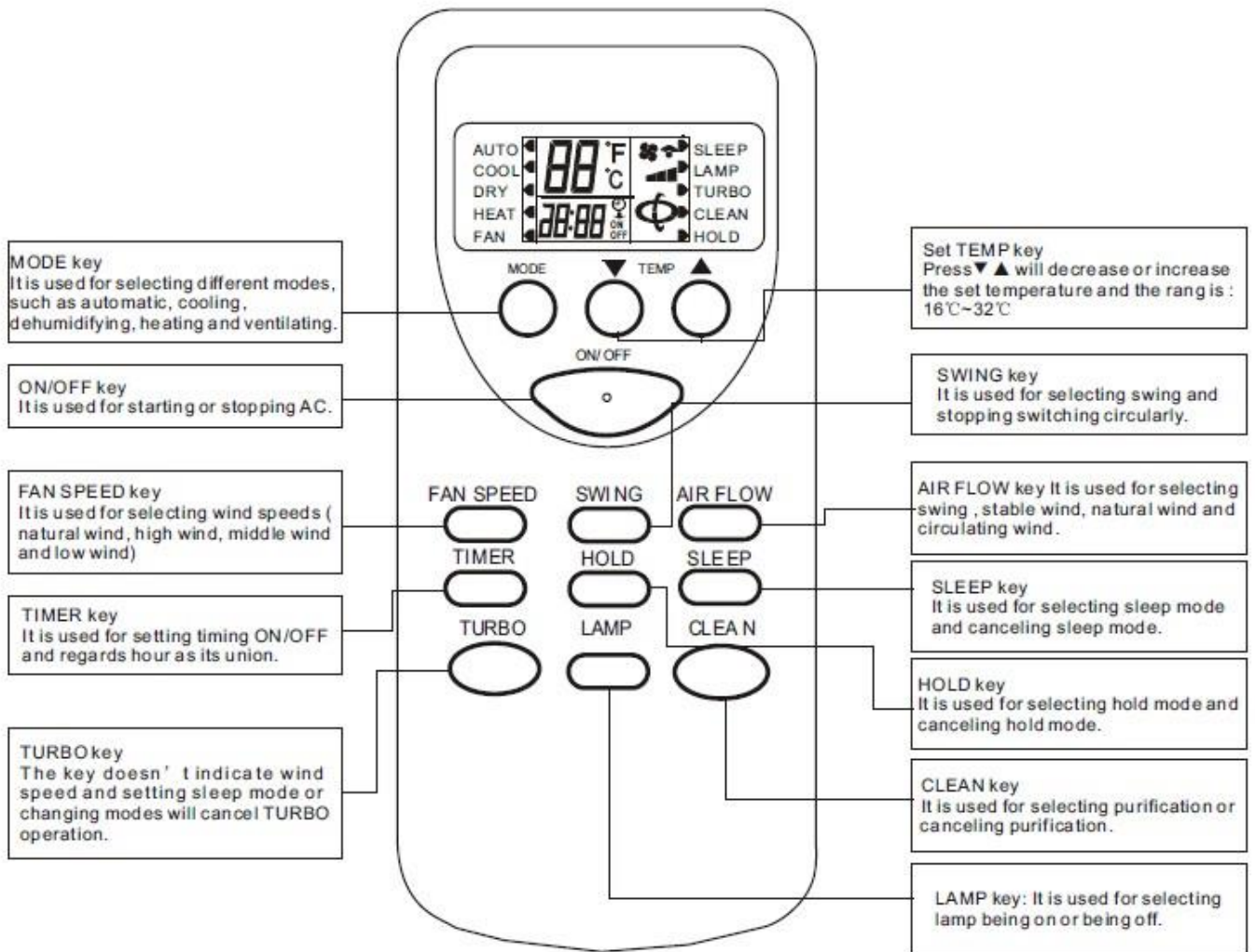

### USE OF REMOTE CONTROLLER

The controller below is the Jingling Common Remote Controller, SWING key, TURBO key, LAMP key and CLEAN key is applicable for special latest developed new models instead of normal ones.

### FUNCTION KEY

A. ON/OFF key:

Press the key and the remote control will switch circularly in the order: ON→OFF→ON. When it is powered on at first from off state to on state, the default setting of work condition is ( The set temperature is 25°C and the mode , wind speed, swing and air door are all automatic and there is no lamp, no turbo, no purification, no sleep, no timing and no hold function ). When it is not powered on firstly from off state to on state, the work condition is as the same as the state before stopping. It will cancel damp, purification, sleep,



turbo and timing running mode.

B. MODE key:

Press the key to switch modes in the order: automatic cooling →dehumidify →heating →ventilating  
→automatic.

C. " ▼ " key:

In dehumidifying mode and automatic mode, pressing the key cannot change the temperature. In other mode, press the key once and the temperature will decrease 1°C in the order: 32°C→31°C→...→17°C  
→16°C .

D. " ▲ " key:

In dehumidifying mode and automatic mode, pressing the key cannot change the temperature. In other mode, press the key once and the temperature will increase 1°C in the order: 16°C→17°C→...→31°C  
→32°C.

E. SWING key:

In dehumidifying mode, the swing mode is in the stable wind mode without change. In other mode, press the key to switch modes in the order: swing → stable wind→ natural wind →swing

F. AIR FLOW key:

The default air flow is in the swing mode when starting firstly and press the key to switch modes in the order: swing →stop →swing.

G. WIND SPEED key:

The default wind speed is in the automatic wind mode when starting firstly. The remote control won't react by pressing the key because the wind speed can't be adjusted and in low speed in dehumidifying mode. In other mode, press the key to switch modes in the order:

Automatic wind→ high speed →middle speed→ low speed →automatic wind

H. TIMER key:

The default mode is in no timing state, press the key to set timing time with hour as its union. The switch order is: 1H→2H→...→24H→cancel→1H.... Press the key to set timing starting in the off state and set timing stopping in the on state. After setting timing function, the time keeps decreasing per hour until the time decreasing to the timing on or timing off and the timing display will be cancelled at the same time. Pressing MODE key can't cancel timing in timing mode which will send out the order of timing time by pressing other key.

I. TURBO key:

The default state for the control is no turbo and the key don't work in the automatic mode, dehumidifying mode and ventilating mode (It will not display any contents and not send out any codes). The control, however, will switch between on and off by pressing the key in other mode. The wind speed isn't indicated in turbo mode and it will be cancelled for changing modes and setting sleep mode.

### J. SLEEP key:

Press the key to switch modes in the order: sleep→ cancel sleep→ sleep. The sleep function won't be cancelled for changing modes. Press the key to set sleep mode and the wind speed will automatically be switched to low speed and it can adjust the wind speed by pressing the WIND SPEED key (except dehumidifying mode).

### K. LOCK key:

The default state is in no LOCK key state, press the key to select modes in order: LOCK key →cancel LOCK key→ LOCK key; In LOCK key mode, all keys except LOCK key of the remote control can't work . (NOTE: In LOCK key mode, the remote and operation panel of the unit both will be locked automatically by pressing the key and press the key again, they will be unlocked. As for the split unit, it only holds the control rather than urgent keys and the panel will make a reaction.)

### L. LAMP key:

The default state is in no LAMP key state, press the key to select modes in order: LAMP key →cancel LAMP key→ LAMP key; In LAMP key mode, pressing MODE key can't cancel the show of LAMP key.

### M. CLEAN key:

The default state is in no purification state, press the key to select modes in order: CLEAN →cancel CLEAN→ CLEAN; In purification mode, pressing CLEAN key can't cancel purification function. Press the key when the remote control is closed, the control will switch modes in the order: CLEAN →cancel CLEAN→ CLEAN; when you stop the unit and turn on the purification switch, except the wind, the stable swing and air door swing speed aren't adjusted.

## 2 Wire Controller

### ZKX-CMVE-05

#### I. Use-method

The control panel of wire controller is responsible for controlling the operation status of the system by the button and displaying the working status of the entire system by its LCD screen, and is responsible for communicating with the control board of the system.



Fig1 Appearance of Wire Controller

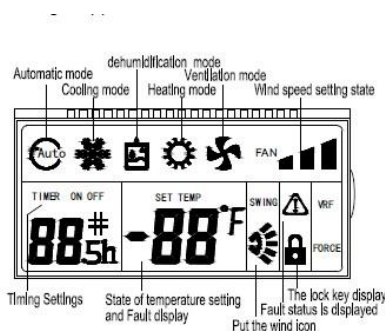

Fig2 LCD display content of Wire Controller

#### Operation and Instruction:

##### "ON/OFF" Button:

- 1) Control the On/Off status of the system.
- 2) Press and hold the On/Off button when the wire controller is powered on, to go into the self-test mode. And then you can release the button.

##### "MODE" Button:

When the air conditioning is powered on, every time you press mode button or the mode button of remote controller, the mode will change in the following sequence.

Auto Mode→Refrigeration→Dehumidification→Heating→Ventilation→Auto Mode

##### "TEMP+" and "TEMP-" Button ("▲", "▼") :

- 1) Boot state, press "▲" and "▼" button, increase/decrease the setting temperature. Refrigeration, Dehumidification, Ventilation and Heating mode. Scope of temperature setting: 16 °C ~ 32 °C; The setting temperature do not adjust in Auto Mode.

- 2) Press the "▲" and "▼" button for 3s simultaneously to lock this button. At this time, it will display the locking icon in LCD. Deactivate this button, and press the "▲" and "▼" button again simultaneously.

##### "TIMER" Button

Set Timing On or Timing Off. The wire controller to set the time range as 1-24h.

- 1) Press the Timer button in the Off status to go into the Timing On for 1 hour, and then press the Timer button plus 1 until it is timing on for 24h. At this time, if you press the Timer button, it will deactivate Timing On.

- 2) Press the Timer button in the On status to go into the Timing Off for 1 hour, and then press the Timer button plus 1 until it is timing off for 24h. At this time, if you press the Timer button, it will deactivate Timing Off.

##### "FAN SPEED" Button:

- 1) The Fan Speed button is valid in the "Cooling mode", "Heating mode" and "Ventilation mode".
- 2) Press the Fan Speed button of the wire controller or the Volume button of the remote controller in the Cooling mode, Heating mode or Ventilation mode, and the volume changes as follows:

High speed → Middle speed → Low speed → Auto wind

- 3) There is no Auto wind in the Ventilation mode.

##### "SWING" Button:

- 1) Press it to display the Swing icon. The Swing icon will swing back and forth.
- 2) Press the Swing button, and the upper and lower wind deflectors will swing within the specified range automatically, and the left and right wind deflectors will swing within the specified range automatically, and press it again to stop the swing.

##### 26°C/CHECK Button Function :

- 1) Short press this button, Enter a state of energy saving of 26 °C, namely the setting temperature is 26 °C. this function under the boot of Refrigeration and Heating mode is effective.
- 2) Long press this button, will enter the query condition; It will exit the query condition, when you press this button again and five seconds is not operating in the condition of the query.

By pressing "▲" and "▼" button to check the temperature in the query condition. 1 is Indoor environment temperature, 2 is Indoor pipe temperature, 3 is outdoor pipe temperature

##### Description of DIP Switch :

	2 ON	2 OFF
3 ON	-4°C	-2°C
3 OFF	2°C	0°C
	ON	OFF
1	The old protocol	The new protocol
4	with power failure memory	with out power failure memory

- 1) The second and third bits of the DIP switch will select the compensation value of the indoor temperature. The compensation value is -4°C when the second and third bits are ON, and the compensation value is 0°C when the second and third bits are OFF. The compensation value is 2°C when the second bit is ON and the third bit is OFF, and the compensation value is -2°C when the second bit is OFF and the third bit is ON (for the wire controller sensor only).
- 2) The first bit of the DIP switch indicates to select the new or old protocol. Light commercial units select the new protocol.
- 3) The fourth bit ON of the DIP switch indicates it is With Power Failure Memory function, and the fourth bit OFF indicates it is Without Power Failure Memory.

NOTE: Just need to dial the code when matching the old type. Detailed please see after-sales guidance !

## II. Installation of Wire Controller

### Safety Precautions

- ! Read the safety precautions carefully before installation.
- ! The following is the important content to be paid for the safety, be sure to follow it.
- ! The meaning of each part:

<b>Warning:</b>	Indicate it may cause the death or serious injury for the improper operation.
<b>Note:</b>	Indicate it may cause the death or serious injury for the improper operation.

- Notes:**
- Please do not install the wire controller in damp or direct sunlight places.
  - Please do not hit, throw and frequent disassembling the wire controller.
  - Please do not operating the wire controller with Wet hand ; Don't make any fluid into the wire controller .
  - Please do not do dismantling the wire controller without authorization. Please consult after-sales maintenance personnel If you have a problem .
  - To prevent water and dust into the wire controller, Affect the wire controller normal use. Please dismantle the wire controller When the indoor decoration and maintenancee .

### Installation and disassembly of the wire controller

#### 1. The installation position and requirements of the wire controller

- 1) Please do not install the wire controller in damp or direct sunlight places.
- 2) Please do not install the wire controller in the places, where is near the high temperature or easy to splash water.
- 3) To avoid the interference of the neighbors' remote controller which has the same model , then cause abnormal work. Please do not install the wire controller where the face up to the window.
- 4) Before installation , please cut off the power which is Buried in the wall mounting holes. The whole installation process does not allow operation with power.
- 5) In order to avoid the unit by reason of electromagnetic interference caused by abnormal work . When wiring , please pay attention to the following matters.
  - A) Ensure that communication line access right, otherwise will lead to communication failures.
  - B) If the air conditioning unit is installed on the places , which is influence by electromagnetic interference . the wire controller signal lines must use shielded twisted-pair cable .
- 6) The standard accessories which is installation need to prepare : installed inside a wall socket bottom box, controller base plate, screw the M4 x 25, control panel.

#### 2. The installation of the wire controller

First of all, the wire controller signal line connection mode is as follows :

- 1) Open interior electrical lifted the lid, and the signal wires through the rubber ring;
- 2) Plug the wire controller signal lines within the five core needle base on the indoor machine circuit boards, and using cable tie line tied tightly fixed.

Next, the wire controller installation steps as shown in the figure below:

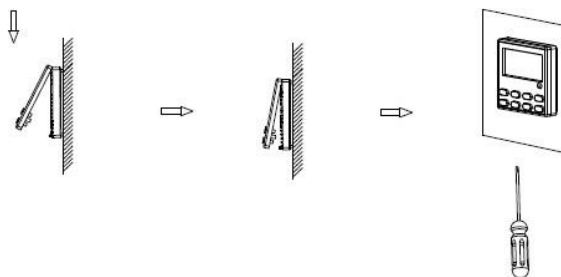
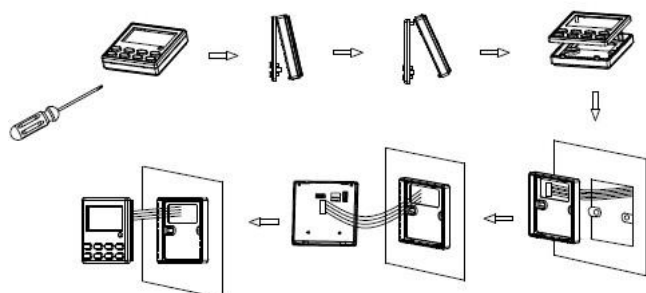

Connect the wire controller in the way as shown in the figure below

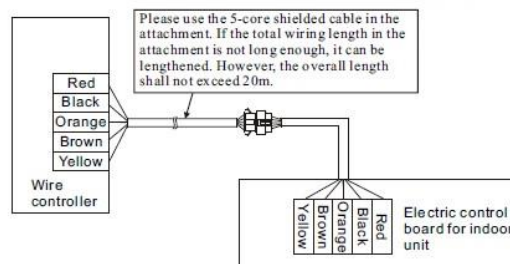

Brief description of the installation process is as follows

- 1) The signal lines of short through rectangle hole of the wire controller bottom plate, and then pull out five core twisted pair from the wall installation hole. Finally connect the line and the other end.
- 2) Use screws M4 x 25 to fix the controller base plate on the mounting holes of the wall.
- 3) Put the wire controller panel and floor buttons together, and this installation is complete. When installation, please reserve a certain length of the line at the bottom of box, to facilitate maintenance later removed.

#### 3. Disassembly of the wire controller

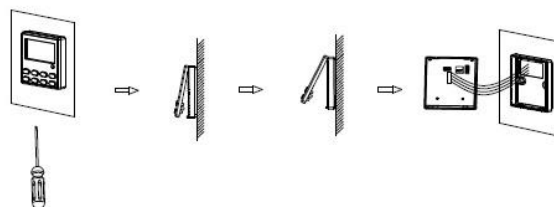

! After the completion of the installation, confirm there is no abnormality for the commissioning, and deliver the instruction to customers for storage.

- Note:**
- It may cause the rear cover deformed if the screw is tightened too much.
  - It is necessary to reserve a certain length for the connecting cable of the wire controller during the installation, so as to take down the wire controller for the maintenance.